



1GB to 8GB
Industrial Grade USB Flash Drive



SLUFDxxxU2TU(I)

Capacity: 1GB - 8GB

USB 2.0 Compliant

LED activity indicator

Customizable for logo/graphic design

High Reliability:

- Guaranteed 2M Write Operations
- Advanced Wear-Leveling
- BCH ECC Engine corrects up to 12 bits/512 Bytes errors
- Automatic Bad Block Management
- Single Level Cell (SLC) NAND Flash Memory
- 10 Year Data Retention

NEBS Level 3 compliant for ESD

- 8KV Contact, 15KV Air

Lot Traceability

Commercial and Industrial Operating Temperature

RoHS-6 Compliant

General Description

STEC's Industrial Grade USB Flash Drive (UFD) is more than just portable storage. Tailored for industrial applications that require high reliability and data throughput, it provides non-volatile, industrial grade solid-state storage in a thumb-drive package. In addition, labeling allows for lot traceability and complete info on the Bill of Materials.

The Industrial Grade UFD is available in an ESD rated enclosure (with LED light indicator) for applications that require NEBS Level 3 compliancy. The ESD-rated enclosure has been tested for immunity from ESD for 8KV contact and 15KV air.

STEC's U2T, state-of-the-art, USB 2.0 flash memory controller is incorporated in the Industrial Grade UFD, providing high data integrity and endurance. The flash management software that is embedded in the controller emulates a hard disk, enabling read/write operations that are identical to a standard, sector-based hard disk. Sophisticated wear leveling algorithms ensures greater flash endurance, while automatic bad block management and a built-in ECC Engine guarantee the highest data reliability. Based on the BCH error correct algorithm, the ECC engine can correct up to 12-bit errors per 512 Bytes.

High performance, high reliability and a controlled Bill-Of-Materials make the Industrial Grade UFD the product of choice in industrial applications, such as POS Workstations, Networking Equipment, automotive diagnostics and Industrial PCs.

The UFD is fully customizable to add a company logo, graphic design, or text. In addition, STEC offers value-added services to OEM customers, such as pre-loaded content and controlled Bill Of Materials.

Ordering Information: USB Flash Drive

Part Number	Capacity
SLUFD1GU2TU(I)	1 GBytes
SLUFD2GU2TU(I)	2 GBytes
SLUFD4GU2TU(I)	4 GBytes
SLUFD8GU2TU(I)	8 GBytes

Legend:

- **SLUFD** = STEC standard USB Flash Drive part number prefix
- **1G/2G/4G/8G** = 1GB / 2GB / 4GB / 8GB Capacity
- **U2T** = STEC U2 controller (2nd Generation)
- **U** = RoHS-6 compliant
- **Part numbers without (I)** = Commercial temperature range (0°C to 70°C)
- **I** = Industrial temperature range (-40°C to 85°C)

Table of Contents

General Description	1
Ordering Information: USB Flash Drive	1
1.0 Introduction	3
2.0 Product Specifications	4
2.1 Mechanical Dimensions.....	4
2.2 Pin Assignment and Description.....	5
2.3 Performance.....	5
2.4 LED Functionality.....	5
2.5 Power Consumption	6
3.0 Theory of Operation	7
3.1 Block Diagram	7
3.1.1 Controller Internal Components	7
3.1.2 Controller External Components.....	8
3.2 Flash Management.....	8
3.2.1 Bad Block Management.....	8
3.2.2 Wear Leveling.....	9
3.2.3 Error Correction/Detection	9
3.3 OS Support.....	10
3.3.1 Using USB Flash Drive with XP Embedded.....	10
3.4 Unique Serial Number	11
4.0 Environmental Specifications	12
4.1 Recommended Operating Conditions	12
4.2 Reliability	12
4.3 Shock, Vibration, and Humidity	12
4.4 Electrostatic Discharge (ESD).....	13
4.5 Mean Time Between Failure (MTBF)	13
4.6 Standards Compliance	13
5.0 Electrical Specifications	14
5.1 Absolute Maximum Ratings.....	14
5.2 DC Characteristics.....	14
5.3 AC Characteristics.....	15
6.0 SCSI Command List	16
7.0 Product Marking	17
7.1 Front Label	17
7.2 Back Label.....	18
7.3 Decoding the BOM Assembly Number.....	19
8.0 Programmed Vendor and Product Names	19
9.0 Contact Information	20
9.1 STEC Worldwide Headquarters	20
9.2 STEC Worldwide Locations.....	20
10.0 Revision History	21

1.0 Introduction

This datasheet includes the following sections:

- *Product Specifications* covers the most referenced specifications, such as mechanical dimension, signal description, and performance.
- *Theory of Operation* explains the Industrial Grade UFD block diagram and flash management features.
- *Environmental Specifications* characterizes the recommended operating conditions, reliability parameters and shock, vibration and humidity parameters.
- *Electrical Specifications* describes the absolute maximum ratings and AC/DC characteristics.
- *Product Marking* describes the marking on the USB Flash Drive.

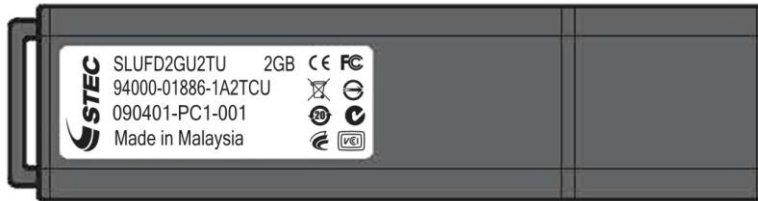

Figure 1: Industrial Grade USB Flash Drive

2.0 Product Specifications

2.1 Mechanical Dimensions

Table 1 and Figure 2 show the mechanical dimensions of the Industrial Grade UFD with ESD-Rated Enclosure.

Table 1: Mechanical dimension

Parameter	ESD-rated enclosure
Length with Cap	66.1 mm (2.602 in) Max
Width	16.60 ± 0.20 mm (0.654 ± 0.008 in)
Height	7.02 ± 0.20mm (0.276 ± 0.008 in)

Units: mm (in)

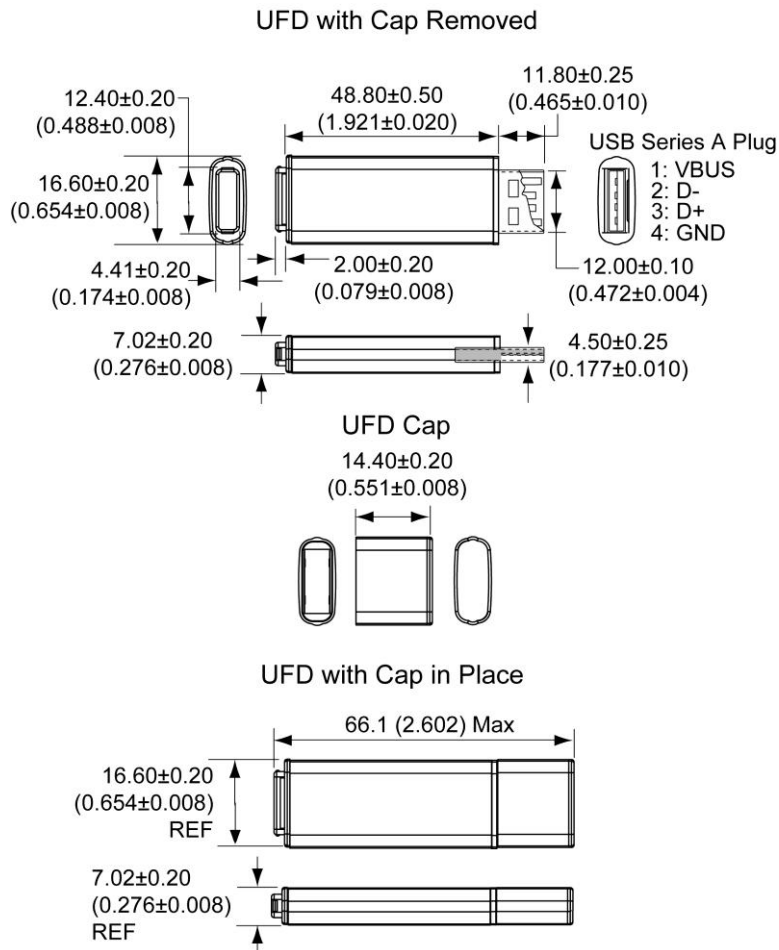

Figure 2: Mechanical dimensions-UFD ESD-Rated enclosure

2.2 Pin Assignment and Description

Table 2: Pin Assignment and Description

Pin Number	Signal Name	Type	Description
1	VBUS	Power	Bus voltage supply
2	D-	I/O	Data line –
3	D+	I/O	Data line +
4	GND	Ground	Ground

2.3 Performance

The Industrial Grade UFD is USB 2.0 high-speed (480Mb/sec) and USB 1.1 full-speed (12Mb/sec) compliant. Measured performance for high-speed can be found in Table 3.

Table 3: Read/Write Performance

Parameter	Value
Sustained Read	up to 30 MB/sec
Sustained Write	up to 20 MB/sec

2.4 LED Functionality

The Industrial Grade UFD with standard enclosure incorporates a LED activity indicator that functions as described below:

- LED flashing: Industrial Grade UFD is transmitting/receiving data or is identification process
- Default LED colors: Blue

2.5 Power Consumption

The power consumption currents listed in Table 4 are for reference only. Power consumption may change according to flash memory used.

Table 4: Power Consumption

Power State	Symbol	Power Consumption (Typical)	Unit
Normal	I _{NORMAL}	70.6	mA
Suspend	I _{SUSPEND}	0.8	mA
Sleep	I _{SLEEP}	0.8	mA
Read	I _{READ}	108.3	mA
Write	I _{WRITE}	160.9	mA

3.0 Theory of Operation

3.1 Block Diagram

The Industrial Grade UFD uses STEC's U2T, state-of-the-art, USB 2.0 controller, and is combined with SLC NAND Flash for optimal device reliability. The controller's firmware supports the latest NAND flash technology from multiple vendors, and is optimized for the highest performance and reliability.

The USB controller consists of the functional blocks as shown in Figure 3. The blocks are described in the paragraphs following the figure.

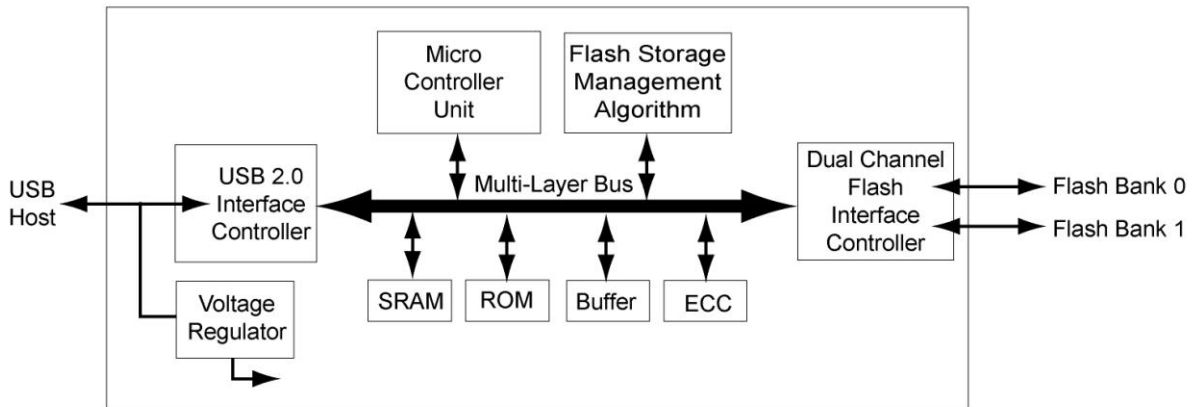

Figure 3: Controller block diagram

3.1.1 Controller Internal Components

- *Microcontroller* which serves as the hardware backbone for the flash controller algorithm.
- *USB 2.0 Interface Controller* with high speed (480 Mbps) device function. This block interfaces with the host system via the USB interface.
- *Flash Interface Controller* that serves as the interface to the NAND flash components. It supports all the major NAND flash memory manufacturers.
- *Flash Storage Management Algorithm Block* is responsible for the flash management, including wear leveling, bad block management, and Error Correction.
- *ECC block* is responsible for on-the-fly error and correction.
- *Sector Buffer* for optimized performance.
- *SRAM* for running controller firmware fast and efficient.
- *ROM* for storing controllers boot code.

3.1.2 Controller External Components

In addition to the functional blocks shown in Figure 3, the Industrial Grade UFD has the following external components:

- *SLC NAND Flash* for the most reliable data storage.
- *Crystal Oscillator 12Mhz*, as the main clock source.

3.2 Flash Management

Since the Industrial Grade UFD provides a standard USB interface to the host, no software integration is required, providing the shortest time-to-market for design engineers.

The firmware of the embedded USB 2.0 controller contains STEC's advanced flash memory management algorithms to ensure the most optimum device performance, reliability and endurance. It was designed to maximize the benefits of flash memory, while at the same time overcoming inherent NAND flash limitations. Implemented in firmware are the below features:

- Flash file system management
- Bad-block management
- Wear-leveling
- Performance optimization

3.2.1 Bad Block Management

Inherent to NAND flash technology are areas (blocks) on the media that cannot be used for storage because of their high error rate. These so-called "bad blocks" are already identified by the flash vendor during manufacturing, but can also be accumulated over time during device operation.

The U2T controller contains a table that lists all the bad blocks on the device (Bad Block Table), and automatically maps out these blocks upon system initialization. During device operation it ensures that newly accumulated bad blocks are also mapped out and added to the Bad Block Table.

Bad block management is 100% transparent to the host application, which will not be aware of the location or existence of bad blocks on the media.

3.2.2 Wear Leveling

The SLC NAND flash devices that are being used in the USB Flash Drive are guaranteed for 100,000 Write/Erase cycles per block. This means that after approximately 100,000 erase cycles, the erase block has a higher probability for errors than the error rate that is typical to the flash. While 100,000 write/erase cycles may be good for consumer data storage, such as digital cameras, MP3 players, etc., it is not sufficient for industrial and embedded applications where data is constantly written to the device and long product life is required.

For example, operating systems that use a file system, will update the File Allocation Table (FAT) every time a write is done to the device. Without any wear leveling in place, the area on the flash where the FAT table is located would wear out faster than other areas, reducing the lifetime of the entire flash device.

To overcome this limitation, the flash management algorithm needs to make sure that each block in the device ages, i.e. is "worn out", at the same rate. The built-in wear leveling scheme makes sure that with every write to the flash, the youngest block is used. This ensures that the full flash media is used uniformly, so that one area of the flash will not reach the endurance limits prematurely before other areas.

3.2.3 Error Correction/Detection

The USB 2.0 controller implements an advanced Error Correction scheme, based on the BHC error correct algorithm. The ECC engine can correct up to 12-bits per 512 Bytes (symbol based). To ensure the fastest performance, correction is done on-the-fly, in hardware only.

Each time the host application writes a sector of 512 bytes to the Industrial Grade UFD, a unique ECC signature is created by the ECC engine and written together with the data to the flash. When the data is read back by the host, the ECC engine creates again the unique ECC signature. It will then compare the original written signature with the newly created signature, and sets an error flag if the two signatures are not the same. Correction of the data is done on-the-fly when the error flag is set, and the data presented to the host will be the same as the original written data an Uncorrectable Bit Error Rate (UBER) of less than 1 in 10^{14} bits, read.

3.3 OS Support

The Industrial Grade UFD is recognized as a removable drive and supports the following Operating Systems, as listed in Table 5.

Table 5: Supported Operating Systems

Operating System	Version
Windows 98/2000/XP/Vista/Windows 7	
Windows XP Embedded	Service Pack 2007
Windows CE	4.2 and 5.0
Windows for POS (WEPOS)	
VxWorks	6.1 and up
Linux	Kernel 2.4 and up

Note: Windows 98 requires driver.

3.3.1 Using USB Flash Drive with XP Embedded

When using USB Flash Disk Drive with Windows XP Embedded, it is recommended that the Enhanced Write Filter (EWF) feature is implemented. The EWF intercepts calls at the sector level, and thereby eliminates many file system updates/writes to the flash. Windows XP Embedded Service Pack 2 Feature Pack 2007 introduced an additional write protect feature, called File Based Write Filter (FBWF). The new FBWF function write-protects embedded devices at the file level, in contrast to the EWF, which has been protecting devices at the sector level.

FBWF and EWF, combined with the built-in wear leveling algorithm, ensure that the maximum life span of the flash device is achieved.

3.4 Unique Serial Number

During manufacturing stage, a unique serial number is written to the USB Flash Disk that includes a date code related to the time of manufacturing.

The serial number uses the following format: [AA][B][C][DD][EE][FFFF][GGGG] Table 6 below describes the parameters of the serial number.

Table 6: Unique Serial Number format

Symbol	Parameter
AA	STEC Reserved (86h)
B	Year (hex)
C	Month (hex)
DD	Day (hex)
EE	Production PC Number (hex)
FFFF	Last 2 Bytes of MAC Address
GGGG	Serial Number, Incremental (hex)

The Serial Number can be obtained through Windows Device Manager or Linux lsusb utility.

4.0 Environmental Specifications

4.1 Recommended Operating Conditions

Table 7: Recommended Operating Conditions

Parameter	Symbol	Min	Typ	Max	Unit
Commercial Operating Temperature	T _A	0	25	70	°C
Industrial Operating Temperature	T _A	-40	-	85	°C
Bus Voltage (5V)	V _{BUS(5V)}	4.75	5.0	5.25	V

4.2 Reliability

Table 8: Reliability

Parameter	Value
Endurance	2M write operations
Uncorrectable Bit Error Rate (UBER)	<1 uncorrectable error per 10 ¹⁴ bits read
Data retention	10 years
Durability	1500 insertions/removals

4.3 Shock, Vibration, and Humidity

Table 9: Shock, Vibration & Humidity

Parameter	Value
Shock	1500G Peak, 0.5m pulse duration, 5 pulses, 6 axes (per JESD22-B110)
Vibration	20G Peak, 20-2000 Hz, 4 cycles per direction (X, Y and Z) (per JESD22-B103)
Humidity	85°C, 85% RH, Vmax for 500 hrs (per JESD22-A101)

4.4 Electrostatic Discharge (ESD)

The Industrial Grade UFD has been tested for immunity from ESD under the conditions described in Table 10.

Table 10: Electrostatic Discharge for UFD

ESD Type	ESD Rated Enclosure (Maximum Discharge)
Contact	8KV
Air	15KV

4.5 Mean Time Between Failure (MTBF)

STEC estimates Mean Time Between Failure (MTBF), using a prediction methodology based on reliability data for the individual components in the USB Flash Drive. Table 11 summarizes the prediction results for the USB Flash Disk Drive, based on the following two methodologies:

- Telcordia Special Report SR-332, Reliability Prediction Procedure for Electronic Equipment.
- MIL-HNBK-217

The analysis was performed using Relex Software.

Table 11: USB Flash Drive MTBF

Product	Condition	MTBF (hours)
SLUFD4GU2TU	Telcordia SR-332, GB, 25°C MIL-HNBK-217	>4,000,000
SLUFD8GU2TU	Telcordia SR-332, GB, 25°C MIL-HNBK-217	>4,000,000

4.6 Standards Compliance

USB Flash Drive complies with the following standards:

- CE - EN 55022/55024
- FCC - Class B for Information Technology
- UL 60950
- RoHS-6
- USB 2.0 – Mass Storage Class

5.0 Electrical Specifications

5.1 Absolute Maximum Ratings

Operation not guaranteed at extreme corner cases.

Table 12: Absolute Maximum Ratings

Parameter	Symbol	Value	Unit
Power Supply Voltage Relative to Ground	V _{BUS}	-0.3 to 5.5V	V
Voltage on D+ and D- Relative to Ground	V _{DATA}	-0.3 to 3.6	V
Ambient Operating Temperature (Commercial)	T _A	0 to +70	°C
Ambient Operating Temperature (Industrial)	T _A	-40 to +85	°C
Storage Temperature	T _{stg}	-40 to +85	°C

5.2 DC Characteristics

Measurements at Recommended Operating Conditions, unless otherwise specified.

Table 13: DC Characteristics for Full-Speed Operation (T_A=25°C, V_{dd}=5V, V_{ss}=0V)

Parameter	Symbol	Test conditions	Min	Typ	Max	Unit
Supply Voltage	V _{BUS}		4.75	5	5.25	V
Input LOW Voltage	V _{IL}		-	-	0.8	V
Input HIGH Voltage	V _{IH}		2.0	-	-	V
Output LOW Voltage	V _{OL}	R _L of 1.5kΩ to 3.6V	-	-	0.3	V
Output HIGH Voltage	V _{OH}	R _L of 15kΩ to GND	2.8	-	3.6	V
Output Signal Crossover Voltage	V _{CRS}		1.3	-	2.0	V

Table 14: DC Characteristics for High-Speed Operation ($T_A=25^\circ\text{C}$, $V_{dd}=5\text{V}$, $V_{ss}=0\text{V}$)

Parameter	Symbol	Test conditions	Min	Typ	Max	Unit
Supply Voltage	V_{BUS}		4.75	5	5.25	V
High Speed Idle Level	V_{HSOI}		-10	-	10	mV
High Speed Data Signaling High	V_{HSOH}		360	-	440	mV
High Speed Data Signaling Low	V_{HSOL}		-10	-	10	mV
Chirp J Level (differential Voltage)	V_{CHIRPJ}		0.7	-	1.1	V
Chirp K Level (differential Voltage)	V_{CHIRPK}		-0.9	-	-0.5	mV

5.3 AC Characteristics

Measurements at Recommended Operating Conditions, unless otherwise specified.

Table 15: AC Characteristics Full Speed

Parameter	Symbol	Min	Typ	Max	Unit
Rise Time	T_{FR}	4	-	20	ns
Fall Time	T_{FF}	4	-	20	ns
Differential Rise and Fall Time Matching	T_{FRFM}	90		111.11	%
Driver Output Resistance	Z_{DRV}	28	-	44	Ω

Table 16: AC Characteristics High Speed

Parameter	Symbol	Min	Typ	Max	Unit
Rise Time (10%~90%)	T_{HSR}	500	-	-	ps
Fall Time (10%~90%)	T_{HSF}	500	-	-	ps
Driver Output Resistance	Z_{HSDRV}	40.5	-	49.5	Ω

6.0 SCSI Command List

Table 17: SCSI Command List

Command List	OpCode	RBC	SPC-2	SPC-3
INQUIRY	12h	√	√	√
MODESENSE(6)	1Ah	√	√	√
MODESENSE(10)	5Ah	-	√	√
PREVENT/ALLOW MEDIUM REMOVAL	1Eh	√	√	√
READ(10)	28h	√	-	-
READ CAPACITY	25h	√	-	-
REQUEST SENSE	03h	-	√	√
START STOP UNIT	1Bh	√	-	-
TEST UNIT READY	00h	√	√	√
WRITE(10)	2Ah	√	-	-
VERIFY(10)	2Fh	√	-	-
SYNC CACHE	35h	√	-	-

7.0 Product Marking

USB Flash Drive will be shipped with standards compliance logos on the front label (Figure 4) and the manufacturing info on the back label (Figure 5), thereby providing lot traceability and full access to the Bill of Material.

The back label of the USB Flash Drive shows the BOM Assembly Number. Table 18 decodes the BOM Assembly Number into the manufacturing info.

7.1 Front Label

STEC USB FLASH DRIVE LABEL SPECIFICATION

1. Label Outline and Dimensions

28.6 mm
9.5 mm
Corner Radius (x4)
0.76mm / 0.03in.
Cyan outline represents DIE LINE
DOES NOT PRINT

2. Pre-printed content and sample

Actual Size Enlargen for viewing

Label Part No. 74510-00241-001

3. Label Material Information

MATERIALS:	2 mil white uncoated mylar Glossy Finish	1 mil transparent adhesive UL/CSA Approved	UV inks
COLOR PALATTE:	<input checked="" type="checkbox"/> One Color Process BLACK 	<input type="checkbox"/> PMS:	PMS 429c PMS 485c Reflex Blue
LABEL ORIENTATION:	Bottom of label comes off roll first		
NOTES:	• Label is to be place on bottom of drive		

STEC UFD STANARD LABEL SPECIFICATION

REVISION:	C	PRODUCT MANAGER:	SCOTT PHILLIPS
REVISION DATE:	MARCH, 2009	SPEC DESIGNER:	TINH NGO
SPECIFICATION #:	62100-00001-001		
LABEL PART #:	74510-00241-001		

THIS INFORMATION IS CONFIDENTIAL AND PROPRIETARY TO STEC AND SHALL NOT BE REPRODUCED OR OTHERWISE DISCLOSED TO ANYONE OTHER THAN STEC EMPLOYEES WITHOUT WRITTEN PERMISSION FROM STEC.

Figure 4: Front Label

7.2 Back Label

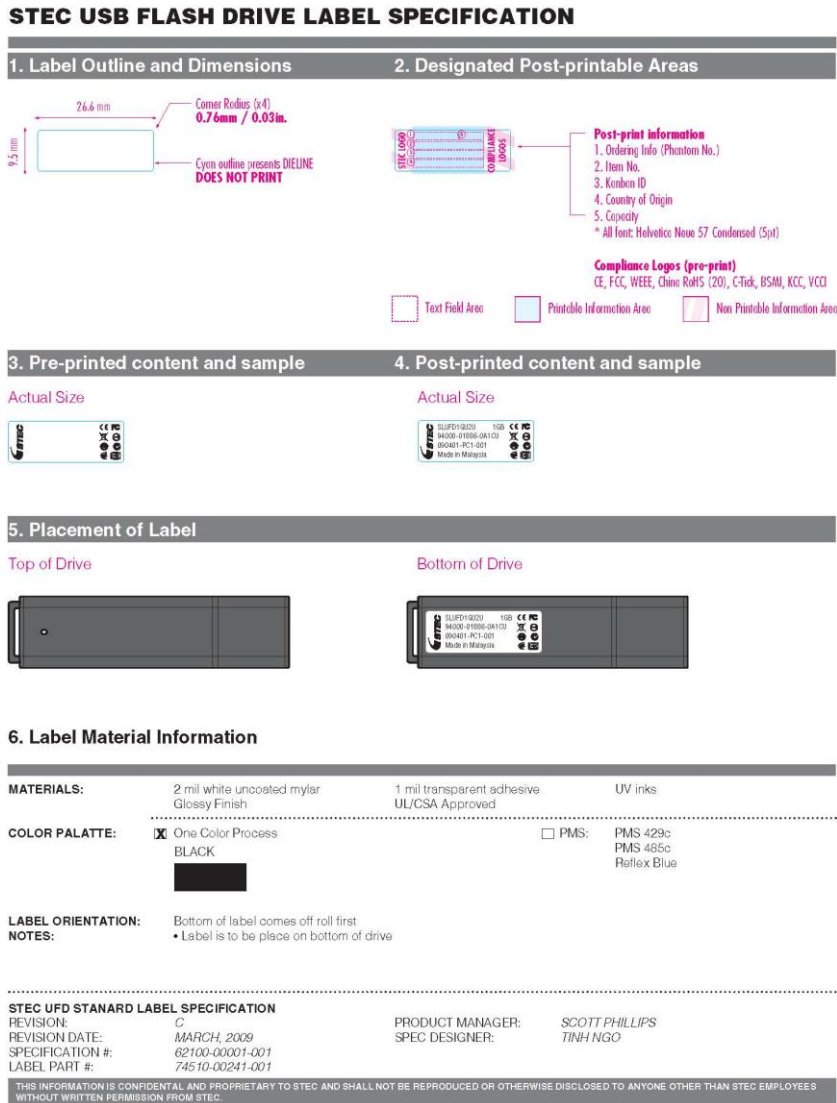

Figure 5: Back Label

7.3 Decoding the BOM Assembly Number

Table 18: BOM Assembly Number info

BOM Assembly Number (Format: ppp00-0xxxx-yyzT(C/I)U)	Description
ppp00	STEC designation for OEM Flash products (ppp is 940 for standard, or customer prefix for custom)
0xxxx	PCB number
yy	Product Revision
z	Capacity Designator (Randomly assigned per PCB number based on designator availability)
T	Model Revision
C, I	Commercial and Industrial Operating Temperature
U	RoHS Compliant

8.0 Programmed Vendor and Product Names

The USB Flash Drive can be manufactured with standard or customer-specific Vendor and Product Names. Table 19 lists the STEC standard names for USB Flash Drive.

The names can be displayed by the OS, for example, Windows XP displays the names in the notifications area in the right corner of the screen the first time the module is installed. Windows Device Manager and the properties of the USB Flash Disk Module also can display the names

Table 19: STEC Standard USB Vendor and Product Names

Parameter	Value
Vendor Name	"STEC"
Product Name	"STEC USB 2.0"

9.0 Contact Information

9.1 STEC Worldwide Headquarters

STEC INC		
3001 Daimler Street	General Support:	1-949-476-1180
Santa Ana, California 92705	Fax Number:	1-949-476-1209
United States of America (USA)	E-mail:	oemsupport@stec-inc.com

9.2 STEC Worldwide Locations

STEC ITALY S. R. L.	STEC TAIWAN	STEC JAPAN G.K.
Via del Caravaggio, 3 20111 Milano Italy	RM1101, 11F, No. 495 Guang-Fu S. Road Taipei Taiwan	Shinyurigaoka-City Building 4-402 1-1-1, Manpukuji, Aso-ku, Kawasaki-shi Kanagawa-ken 215-0004 Japan
Phone: +39 02 497 56 213	Phone: +886 2 8780 8000 Ext. 1101 Fax: +886 2 8725 7711	Phone: +81 44-959-2883 Fax: +81 44-959-2887
STEC MALAYSIA	STEC CHINA	
STEC Technology Sdn Plot 107 Bayan Lepas Industrial Park Phase 4 11900 Penang, Malaysia	RM1805, 18F Bund Centre 222 Yan An Road East HuangPu District Shanghai 200002 P.R. China	
Phone: +60 (4) 8887888	Phone: +86 21 6132 3892 Ext. 629 Fax: +86 21 6335 1336	

10.0 Revision History

Revision	Date	Description
-101	02/14/2011	Preliminary release.
-102	02/23/2011	Label on photo of UFD updated. Extended changed to Industrial.Temperature. “T” designator added to BOM Assembly Number.
-103	04/08/2011	UBER, Endurance, and ECC Engine corrected (paper error only).
-104	04/26/2011	Photo edited to increased dpi. Preliminary notice removed.
-105	06/07/2011	Logo updated.

DISCLAIMER OF LIABILITY

STEC™ Inc. reserves the right to make changes to specifications and product descriptions such as but not limited to numbers, parameters and other technical information contained herein without notice. Please contact the STEC™ Inc. sales office to obtain the latest specifications. STEC™ Inc. grants no warranty with respect to this datasheet, neither explicit or implied, and is not liable for direct or indirect damages. Some states do not grant the exclusion of incidental damages and as such this statement may not be valid in such states. The provisions of the datasheet do not convey to the purchaser of the device any license under any patent rights or other intellectual property rights of STEC Inc. or others.

EXPORT ADMINISTRATION REGULATIONS

The information provided may be subject to United States Export Controls. Such information should not be downloaded or exported (i), into (or to a national or resident of) Cuba, Iraq, Libya, North Korea, Iran, Syria, or any other country to which the United States has embargoed goods; or given to (ii), anyone on the United States Treasury Department's list of Specially Designated Nationals or the U.S. Commerce Department's Table of Deny Orders. By using the information, you represent and warrant that you are not located in, under the control of, or a national or resident of any such country or on any such list.

COPYRIGHT NOTICE

Copyright © 2011 by STEC™ Inc. All rights reserved. Information contained in this document, including but not limited to any instructions, descriptions and product specifications, is considered proprietary and confidential to STEC™, Inc. and shall not be modified, used, copied, reproduced or disclosed in whole or in part, in any form or by any means, electronic or mechanical, for any purpose, without the written consent of STEC™ Inc