



1GB to 16GB  
USB Flash Module



# SLUFM<sub>xxx</sub>U2TU(I)-y

USB Solid-State Flash Disk

Capacity: 1GB - 16GB

USB 2.0 Compliant

Form Factors:

- Horizontal Mount
- Standard 2x5 or Hirose 9-Pin Connector
- 2x Planar TSOP Flash or 2x Stacked TSOP Flash

High Reliability:

- Guaranteed 2M Write Operations
- Advanced Wear-Leveling
- BCH ECC Engine corrects up to 12 bits/512 Bytes errors
- Automatic Bad Block Management
- Single Level Cell (SLC) NAND Flash Memory
- 10 Year Data Retention

Unique Serial Number

Commercial and Industrial Operating Temperature

RoHS-6 Compliant

[www.stec-inc.com](http://www.stec-inc.com)

## General Description

USB Flash Module (UFM) provides non-volatile, solid-state storage in a compact design, making it perfectly suited for embedded applications. The standard USB 2.0 interface provides designers with a true plug-n-play storage device, allowing for short design cycles and fast time to market.

STEC's U2T, state-of-the-art, USB 2.0 flash memory controller is incorporated in the UFM, providing high data reliability and endurance. The flash management software that is embedded in the controller emulates a hard disk, enabling read/write operations that are identical to a standard, sector-based hard disk. Sophisticated wear leveling algorithms ensures greater flash endurance, while automatic bad block management and a built-in ECC Engine guarantee the highest data reliability. Based on a BCH error correct algorithm, the ECC engine can correct up to 12-bit errors and per 512 Bytes.

USB Flash Module is available with a Standard 2x5 connector (2.54mm pitch) or a Hirose 9-pin connector.

High performance, high reliability and low cost per MByte make the USB Flash Module the product of choice in embedded applications, such as Gaming, POS Workstations, Networking Equipment and Industrial PCs.

STEC offers value-added services to OEM customers, such as customized form factors and test solutions, custom firmware, controlled Bill Of Materials, customer-specific labeling and serialization.

## Ordering Information: USB Flash Module

Part Number	Flash Placement	Capacity
SLUFM1GU2TU(I)-y	2x Planar TSOP Flash	1 GB
SLUFM2GU2TU(I)-y	2x Planar TSOP Flash	2 GB
SLUFM4GU2TU(I)-y	2x Planar TSOP Flash	4 GB
SLUFM8GU2TU(I)-y	2x Planar TSOP Flash	8 GB
SLUFM16GU2TU-A	2x Stacked TSOP Flash	16 GB

### Legend:

- **SLUFM** = STEC standard USB Flash Module part number prefix
- **1G/2G/4G/8G/16G** = 1GB / 2GB/ 4GB/ 8GB / 16GB Capacity
- **U2T** = STEC U2 controller (2<sup>nd</sup> Generation)
- **U** = RoHS-6 compliant
- **Part numbers without (I)** = Commercial temperature range (0°C to 70°C)
- **I** = Industrial temperature range (-40°C to 85°C)
- **(y) = A** for Standard 2x5 connector      **(y) = C** for Hirose 9-pin connector

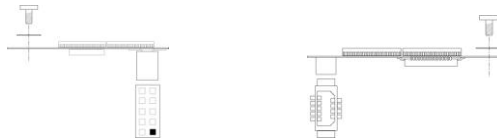

**Note:** 16GB is available with Commercial Temperature Range and standard connector only.

**Table of Contents**

**General Description ..... 1**

**Ordering Information: USB Flash Module ..... 1**

**1.0 Introduction..... 3**

**2.0 Product Specifications ..... 4**

    2.1 Mechanical Dimensions..... 4

        2.1.1 Standard 2x5 Connector Form Factor ..... 4

        2.1.2 Hirose 9-Pin Connector Form Factor ..... 5

    2.2 Pin Assignment..... 6

        2.2.1 Standard 2x5 Connector ..... 6

        2.2.2 Hirose 9-Pin Connector..... 6

    2.3 Signal Description..... 6

    2.4 Performance ..... 7

    2.5 Power Consumption ..... 7

**3.0 Theory of Operation ..... 8**

    3.1 Block Diagram ..... 8

        3.1.1 Controller Internal Components ..... 8

        3.1.2 Controller External Components..... 9

    3.2 Flash Management..... 9

        3.2.1 Bad Block Management..... 9

        3.2.2 Wear Leveling ..... 10

        3.2.3 Error Correction..... 10

    3.3 OS and Boot Support ..... 11

        3.3.1 Using USB Flash Module with XP Embedded ..... 11

    3.4 Unique Serial Number ..... 12

**4.0 Environmental Specifications..... 13**

    4.1 Recommended Operating Conditions ..... 13

    4.2 Reliability ..... 13

    4.3 Shock, Vibration, and Humidity ..... 13

    4.4 Electrostatic Discharge (ESD)..... 14

    4.5 Mean Time Between Failure (MTBF) ..... 14

    4.6 Standards Compliance ..... 14

**5.0 Electrical Specifications ..... 15**

    5.1 Absolute Maximum Ratings..... 15

    5.2 DC Characteristics..... 15

    5.3 AC Characteristics..... 16

**6.0 SCSI Command List ..... 17**

**7.0 Evaluating USB Flash Module ..... 18**

**8.0 Product Marking ..... 19**

**9.0 Programmed Vendor and Product Names ..... 21**

**10.0 Contact Information..... 22**

    10.1 STEC Worldwide Headquarters ..... 22

    10.2 STEC Worldwide Locations..... 22

**11.0 Revision History ..... 23**

## 1.0 Introduction

This datasheet includes the following sections:

- *Product Specifications* covers the most referenced specifications, such as mechanical dimensions, ball assignment, signal description, and performance.
- *Theory of Operation* explains the USB Flash Module block diagram, and flash management features.
- *Environmental Specifications* characterizes the recommended operating conditions, reliability parameters and shock, vibration and humidity parameters.
- *Electrical Specifications* describes the absolute maximum ratings and AC/DC characteristics.
- *Evaluating USB Flash Module* describes how designers can evaluate the USB Flash Module if there is no Standard 2x5 or Hirose 9-pin connector yet available on the hardware design.
- *Product Marking* describes the marking on the USB Flash Module.



Figure 1: USB Flash Module

## 2.0 Product Specifications

### 2.1 Mechanical Dimensions

#### 2.1.1 Standard 2x5 Connector Form Factor

Table 1 and Figure 2 show the mechanical dimensions of the USB Flash Module with Standard 2x5 connector.

Table 1: Mechanical Dimensions, Standard 2x5 Connector

Parameter		Value
Length		38.00 ± 0.15 mm (1.496 ± 0.006 in)
Width		23.00 ± 0.15 mm (0.906 ± 0.006 in)
Height	2x Planar TSOP Flash	10.27 mm (0.404 in) max
	2x Stacked TSOP Flash	11.16 mm (0.439 in) max

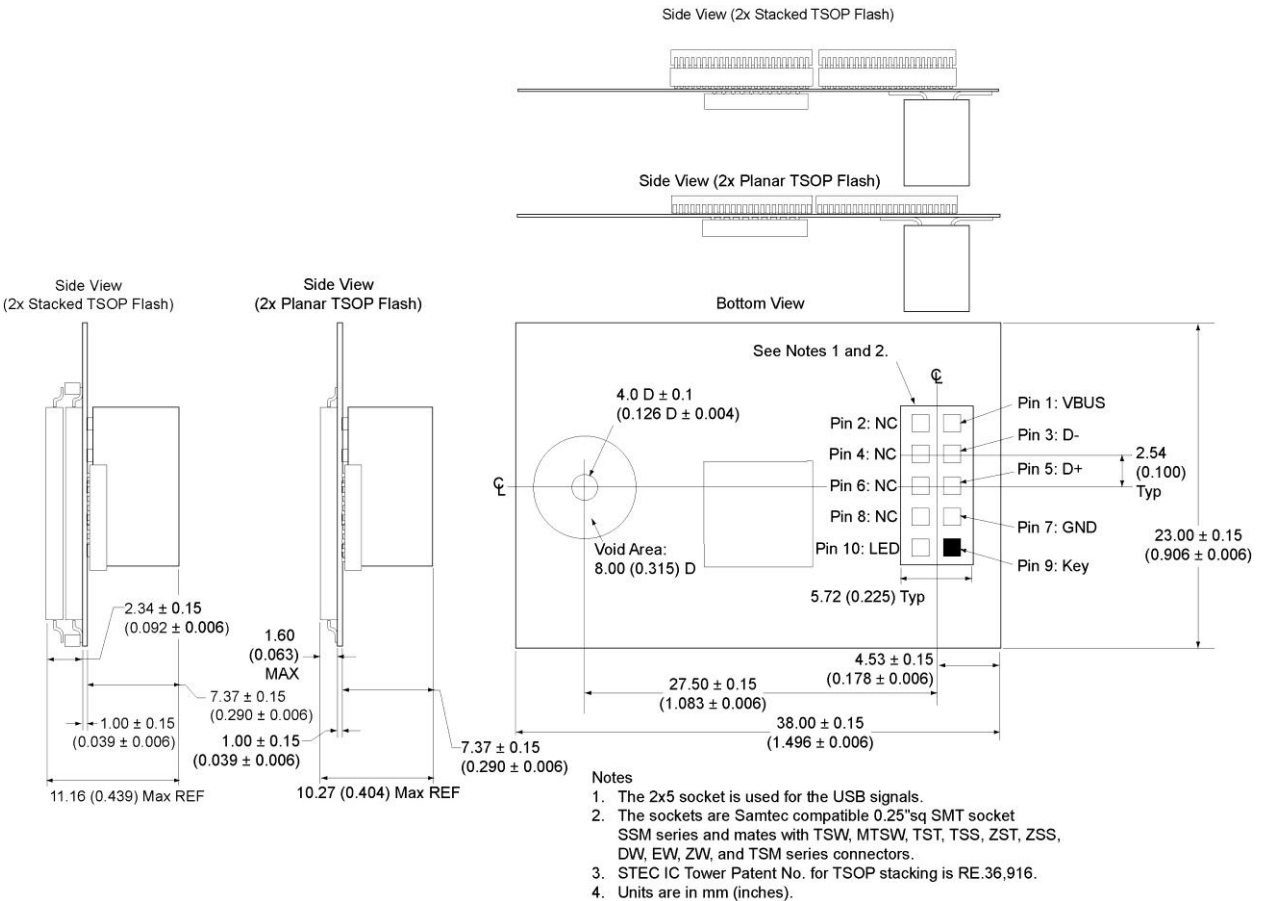

Figure 2: Mechanical Dimensions, Standard 2x5 Connector

2.1.2 Hirose 9-Pin Connector Form Factor

Table 2 and Figure 3 show the mechanical dimensions of the USB Flash Module with Hirose 9-pin connector.

Table 2: Mechanical Dimensions, Hirose 9-pin Connector

Parameter	Value
Length	38.00 ± 0.15 mm (1.496 ± 0.006 in)
Width	23.00 ± 0.15 mm (0.906 ± 0.006 in)
Height	5.97 mm (0.235 in) max

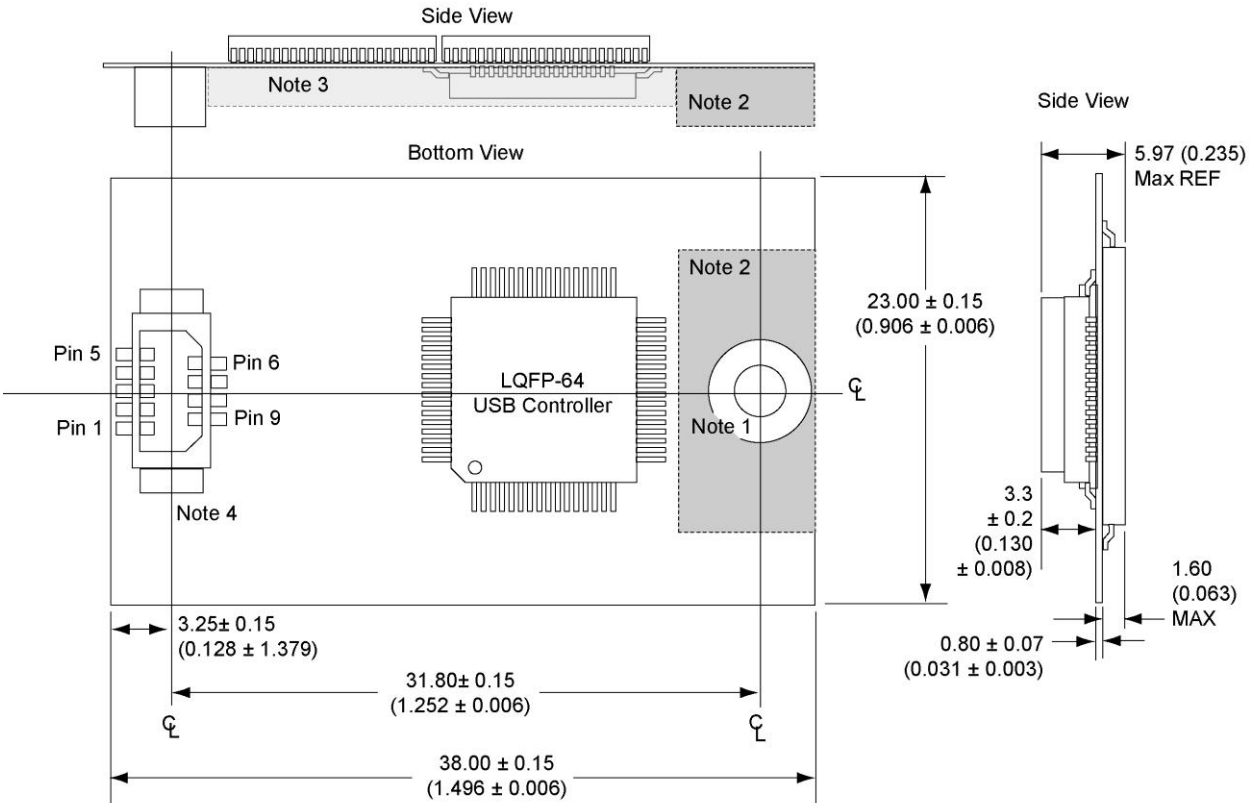

- Notes
- Hole for M2.5 x 4 mm panhead machine screw.
    - 2.9 mm drill diameter.
    - 5.56 mm plated annular ring top and bottom of PCB.
    - Main board will use threaded standoff.
    - Connect annular ring to ground.
    - Topside Keepout of 6.3 mm (0.248 in) circular area.
  - Standoff Keep Out: of 15.24 x 7.37 mm (0.60 x 0.29 in).
  - Component area on bottom side region extends 3.66 mm (0.145 in) below PCB.
  - Hirose DF9-9S-1V(61) Receptacle.
  - Units are in mm (inches).

Figure 3: Mechanical Dimensions, Hirose 9-pin Connector

## 2.2 Pin Assignment

### 2.2.1 Standard 2x5 Connector

Table 3: Standard 2x5 Pin Assignment

Pin Number	Signal Name	Pin Type	Pin Number	Signal Name	Pin Type
1	VBUS	Power	6	NC	I/O
2	NC	—	7	GND	Ground
3	D-	I/O	8	NC	—
4	NC	—	9	Key	Blocked Pin
5	D+	I/O	10	LED	I/O

### 2.2.2 Hirose 9-Pin Connector

Table 4: Hirose 9-Pin Assignment

Pin Number	Signal Name	Pin Type	Pin Number	Signal Name	Pin Type
1	NC	—	6	GND	Ground
2	NC	—	7	D+	I/O
3	LED	I/O	8	D-	I/O
4	NC	—	9	GND	Ground
5	VBUS	Power	—		

## 2.3 Signal Description

Table 5: Signal Description

Signal Name	Type	Pin Number (Standard 2x5)	Pin Number (Hirose 9-pin)	Description
VBUS	Power	1	5	Bus voltage supply from source
D-	I/O	3	8	Data line –
D+	I/O	5	7	Data line +
GND	Ground	7	6, 9	Ground
NC	Open	2, 4, 6, 8,	1, 2, 4	No Connect
Key	Open	9	—	Alignment pin
LED	I/O	10	3	Activity indicator Can be connected to LED on host board

## 2.4 Performance

The Industrial Grade UFD is USB 2.0 high-speed (480Mb/sec) and USB 1.1 full-speed (12Mb/sec) compliant. Measured performance for high-speed can be found in Table 6.

Table 6: Read/Write Performance

Parameter	Value
Sustained Read	up to 30 MB/sec
Sustained Write	up to 20 MB/sec

## 2.5 Power Consumption

The power consumption currents listed in Table 7 are for reference only. Power consumption may change according to flash memory used.

Table 7: Power Consumption

Power State	Symbol	Power Consumption for 1GB-8GB Capacities (Typical)	Power Consumption for 16GB Capacity (Typical)	Unit
Normal	I <sub>NORMAL</sub>	70.6	70.8	mA
Suspend	I <sub>SUSPEND</sub>	0.8	0.9	mA
Sleep	I <sub>SLEEP</sub>	0.8	0.9	mA
Read	I <sub>READ</sub>	108.3	114.5	mA
Write	I <sub>WRITE</sub>	160.9	167.3	mA

### 3.0 Theory of Operation

#### 3.1 Block Diagram

The USB Flash Module uses STEC's U2T, state-of-the-art, USB 2.0 controller, and is combined with SLC NAND Flash for optimal device reliability. The controller's firmware supports the latest NAND flash technology from multiple vendors, and is optimized for the highest performance and reliability.

The USB Flash Module controller consists of the functional blocks shown in Figure 4 and described below.

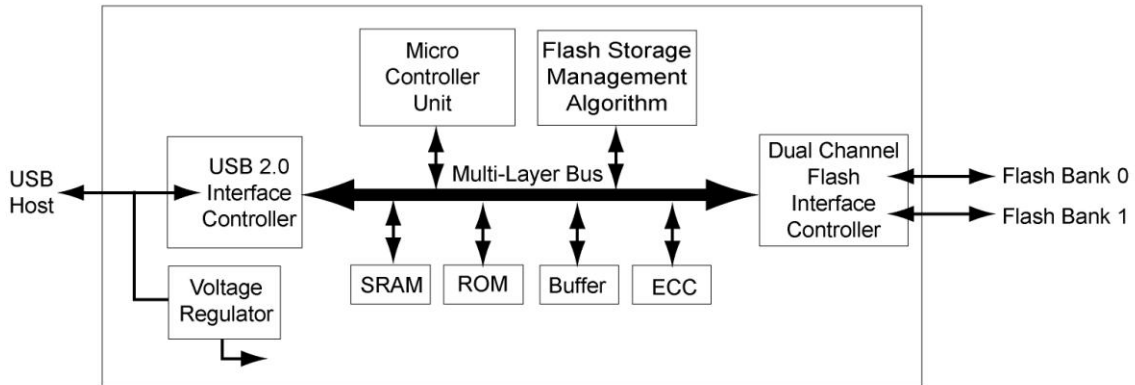

Figure 4: Controller block diagram

##### 3.1.1 Controller Internal Components

- *Microcontroller* which serves as the hardware backbone for the flash controller algorithm.
- *USB 2.0 Interface Controller* with high speed (480 Mbps) device function. This block interfaces with the host system via the USB interface.
- *Flash Interface Controller* that serves as the interface to the NAND flash components. It supports all the major NAND flash memory manufacturers.
- *Flash Storage Management Algorithm Block* is responsible for the flash management, including wear leveling, bad block management, and Error Detection and Correction.
- *ECC block* is responsible for on-the-fly error correction.
- *Sector Buffer* for optimized performance.
- *SRAM* for running controller firmware fast and efficient.
- *ROM* for storing controllers boot code.

### 3.1.2 Controller External Components

In addition to the functional blocks shown in Figure 4, the USB Flash Module has the following external components:

- *SLC NAND Flash* for the most reliable data storage.
- *Crystal Oscillator 12Mhz*, as the main clock source.

### 3.2 Flash Management

Since the USB Flash Module provides a standard USB interface to the host, no software integration is required, providing the shortest time-to-market for design engineers.

The firmware of the embedded USB 2.0 controller contains STEC's advanced flash memory management algorithms to ensure the most optimum device performance, reliability and endurance. It was designed to maximize the benefits of flash memory, while at the same time overcoming inherent NAND flash limitations. Implemented in firmware are the below features:

- Flash file system management
- Bad-block management
- Wear-leveling
- Performance optimization

#### 3.2.1 Bad Block Management

Inherent to NAND flash technology are areas (blocks) on the media that cannot be used for storage because of their high error rate. These so-called "bad blocks" are already identified by the flash vendor during manufacturing, but can also be accumulated over time during device operation.

The USB 2.0 controller contains a table that lists all the bad blocks on the device (Bad Block Table), and automatically maps out these blocks upon system initialization. During device operation it ensures that newly accumulated bad blocks are also mapped out and added to the Bad Block Table.

Bad block management is 100% transparent to the host application, which will not be aware of the location or existence of bad blocks on the media.

### 3.2.2 Wear Leveling

The SLC NAND flash devices that are being used in the USB Flash Module are guaranteed for 100,000 Write/Erase cycles per block. This means that after approximately 100,000 erase cycles, the erase block has a higher probability for errors than the error rate that is typical to the flash. While 100,000 write/erase cycles may be good for consumer data storage, such as digital cameras, MP3 players, etc., it is not sufficient for industrial and embedded applications where data is constantly written to the device and long product life is required.

For example, operating systems that use a file system, will update the File Allocation Table (FAT) every time a write is done to the device. Without any wear leveling in place, the area on the flash where the FAT table is located would wear out faster than other areas, reducing the lifetime of the entire flash device.

To overcome this limitation, the flash management algorithm needs to make sure that each block in the device ages, i.e. is "worn out", at the same rate. The built-in wear leveling scheme makes sure that with every write to the flash, the youngest block is used. This ensures that the full flash media is used uniformly, so that one area of the flash will not reach the endurance limits prematurely before other areas.

### 3.2.3 Error Correction

The USB 2.0 controller implements an advanced Error Correction scheme, based on the BCH error correct algorithm. The ECC engine can correct up to 12 bits per 512 Bytes (symbol based). To ensure the fastest performance, correction is done on-the-fly, in hardware only.

Each time the host application writes a sector of 512 bytes to the USB Flash Module, a unique ECC signature is created by the ECC engine and written together with the data to the flash. When the data is read back by the host, the ECC engine creates again the unique ECC signature. It will then compare the original written signature with the newly created signature, and sets an error flag if the two signatures are not the same. Correction of the data is done on-the-fly when the error flag is set, and the data presented to the host will be the same as the original written data. This powerful Error Correction scheme results in an Uncorrectable Bit Error Rate (UBER) of less than 1 in  $10^{14}$  bits, read.

### 3.3 OS and Boot Support

USB Flash Module can be used as the OS boot and main storage device for most Microsoft Operating Systems, as well as most embedded Operating Systems, as listed in Table 8. In both modes the USB Flash Module is recognized as fixed hard drive in the system.

Table 8: Supported Operating Systems

Operating System	Secondary Storage	Boot	Version
Windows 7	√	TBD	
Windows XP Pro/Vista	√	√	
Windows XP Embedded	√	√	Service Pack 2007
Windows CE	√	√	4.2 and 5.0
Windows for POS (WEPOS)	√	-	
VxWorks	√	√	6.1 and up
Linux	√	√	Kernel 2.4 and up

**Note:** When using the USB Flash Module as the OS boot device, it should be verified that the system BIOS supports booting from a USB device. Please contact your BIOS vendor to verify this.

#### 3.3.1 Using USB Flash Module with XP Embedded

When using USB Flash Module with Windows XP Embedded, it is recommended that the Enhanced Write Filter (EWF) feature is implemented. The EWF intercepts calls at the sector level, and thereby eliminates many file system updates/writes to the flash. Windows XP Embedded Service Pack 2 Feature Pack 2007 introduced an additional write protect feature, called File Based Write Filter (FBWF). The new FBWF function write-protects embedded devices at the file level, in contrast to the EWF, which has been protecting devices at the sector level.

FBWF and EWF, combined with the built-in wear leveling algorithm, ensure that the maximum life span of the flash device is achieved.

### 3.4 Unique Serial Number

During manufacturing stage, a unique serial number is written to the USB Flash Module that includes a date code related to the time of manufacturing.

The serial number uses the following format: [AA][B][C][DD][EE][FFFF][GGGG]. Table 9 below describes the parameters of the serial number.

Table 9: Unique Serial Number format

Symbol	Parameter
AA	STEC Reserved (86h)
B	Year (hex)
C	Month (hex)
DD	Day (hex)
EE	Production PC Number (hex)
FFFF	Last 2 Bytes of MAC Address
GGGG	Serial Number, Incremental (hex)

The Serial Number can be obtained through Windows Device Manager or Linux lsusb utility.

## 4.0 Environmental Specifications

### 4.1 Recommended Operating Conditions

Table 10: Recommended Operating Conditions

Parameter	Symbol	Min	Typ	Max	Unit
Commercial Operating Temperature	T <sub>A1</sub>	0	25	70	°C
Industrial Operating Temperature	T <sub>A2</sub>	-40	-	85	°C
Bus Voltage (5V)	V <sub>BUS(5V)</sub>	4.75	5.0	5.25	V

### 4.2 Reliability

Table 11: Reliability

Parameter	Value
Endurance	2M write operations
Uncorrectable Bit Error Rate (UBER)	<1 uncorrectable error per 10 <sup>14</sup> bits read
Data retention	10 years

### 4.3 Shock, Vibration, and Humidity

Table 12: Shock, Vibration & Humidity

Parameter	Value
Shock	1500G Peak, 0.5m pulse duration, 5 pulses, 6 axes (per JESD22-B110)
Vibration	20G Peak, 20-2000 Hz, 4 cycles per direction (X, Y and Z) (per JESD22-B103)
Humidity	85°C, 85% RH, Vmax for 500 hrs (per JESD22-A101)

#### 4.4 Electrostatic Discharge (ESD)

USB Flash Module has been tested and approved for immunity from ESD under the conditions described in Table 13 below.

Table 13: ESD Rating for USB Flash Module

ESD Type	Value (KV)
Air	2, 4, 8
Contact	2, 4

#### 4.5 Mean Time Between Failure (MTBF)

STEC estimates Mean Time Between Failure (MTBF), using a prediction methodology based on reliability data for the individual components in the USB Flash Module. Table 14 below summarizes the prediction results for the USB Flash Module, based on the following two methodologies:

- Telcordia Special Report SR-332, Reliability Prediction Procedure for Electronic Equipment.
- MIL-HNBK-217

The analysis was performed using Relex Software.

Table 14: USB Flash Module MTBF

Product	Condition	MTBF (hours)
SLUFM4GU2TU-A	Telcordia SR-332, GB, 25°C, MIL-HNBK-217	>8,000,000
SLUFM8GU2TU-A	Telcordia SR-332, GB, 25°C, MIL-HNBK-217	>7,000,000

#### 4.6 Standards Compliance

USB Flash Module complies with the following standards:

- CE - EN 55022/55024
- FCC - Class B for Information Technology
- UL 60950
- RoHS-6
- USB 2.0 – Mass Storage Class

## 5.0 Electrical Specifications

### 5.1 Absolute Maximum Ratings

Operation not guaranteed at extreme corner cases.

Table 15: Absolute Maximum Ratings

Parameter	Symbol	Value	Unit
Power Supply Voltage Relative to Ground	V <sub>BUS</sub>	-0.3 to 5.5	V
Voltage on D+ and D- Relative to Ground	V <sub>DATA</sub>	-0.3 to 3.6	V
Ambient Operating Temperature (Commercial)	T <sub>A1</sub>	0 to +70	°C
Ambient Operating Temperature (Industrial)	T <sub>A2</sub>	-40 to +85	°C
Storage Temperature	T <sub>stg</sub>	-40 to +85	°C

### 5.2 DC Characteristics

Measurements at Recommended Operating Conditions, unless otherwise specified.

Table 16: DC Characteristics for Full-Speed Operation (T<sub>A</sub>=25°C, V<sub>dd</sub>=5V, V<sub>ss</sub>=0V)

Parameter	Symbol	Test conditions	Min	Typ	Max	Unit
Supply Voltage	V <sub>BUS</sub>		4.75	5	5.25	V
Input LOW Voltage	V <sub>IL</sub>		-	-	0.8	V
Input HIGH Voltage	V <sub>IH</sub>		2.0	-	-	V
Output LOW Voltage	V <sub>OL</sub>	R <sub>L</sub> of 1.5kΩ to 3.6V	-	-	0.3	V
Output HIGH Voltage	V <sub>OH</sub>	R <sub>L</sub> of 15kΩ to GND	2.8	-	3.6	V
Output Signal Crossover Voltage	V <sub>CRS</sub>		1.3	-	2.0	V

Table 17: DC Characteristics for High-Speed Operation ( $T_A=25^\circ\text{C}$ ,  $V_{dd}=5\text{V}$ ,  $V_{ss}=0\text{V}$ )

Parameter	Symbol	Test conditions	Min	Typ	Max	Unit
Supply Voltage	$V_{BUS}$		4.75	5	5.25	V
High Speed Idle Level	VHSOI		-10	-	10	mV
High Speed Data Signaling High	VHSOH		360	-	440	mV
High Speed Data Signaling Low	VHSOL		-10	-	10	mV
Chirp J Level (differential Voltage)	VCHIRPJ		0.7	-	1.1	V
Chirp K Level (differential Voltage)	VCHIRPK		-0.9	-	-0.5	mV

### 5.3 AC Characteristics

Measurements at Recommended Operating Conditions, unless otherwise specified.

Table 18: AC Characteristics Full Speed

Parameter	Symbol	Min	Typ	Max	Unit
Rise Time	$T_{FR}$	4	-	20	ns
Fall Time	$T_{FF}$	4	-	20	ns
Differential Rise and Fall Time Matching	$T_{FRFM}$	90		111.11	%
Driver Output Resistance	$Z_{DRV}$	28	-	44	$\Omega$

Table 19: AC Characteristics High Speed

Parameter	Symbol	Min	Typ	Max	Unit
Rise Time (10%~90%)	$T_{HSR}$	500	-	-	ps
Fall Time (10%~90%)	$T_{HSF}$	500	-	-	ps
Driver Output Resistance	$Z_{HSDRV}$	40.5	-	49.5	$\Omega$

## 6.0 SCSI Command List

Table 20: SCSI Command List

Command List	OpCode	RBC	SPC-2	SPC-3
INQUIRY	12h	√	√	√
MODESENSE(6)	1Ah	√	√	√
MODESENSE(10)	5Ah	-	√	√
PREVENT/ALLOW MEDIUM REMOVAL	1Eh	√	√	√
READ(10)	28h	√	-	-
READ CAPACITY	25h	√	-	-
REQUEST SENSE	03h	-	√	√
START STOP UNIT	1Bh	√	-	-
TEST UNIT READY	00h	√	√	√
WRITE(10)	2Ah	√	-	-
VERIFY(10)	2Fh	√	-	-
SYNC CACHE	35h	√	-	-

## 7.0 Evaluating USB Flash Module

Adapters are available for customers that do not have the hardware layout ready for the USB Flash Module. The adapter shown in Figure 5 uses a Standard 2x5 connector and enables inserting the USB Flash Module into a standard USB port on a desktop or laptop PC. Inquire for adapters that use the Hirose 9-pin connector.



*Figure 5: USB Flash Module Adapter*

The adapters can be ordered with the following ordering information:

- SLUFDM-2x5-ADPT-A for modules with Standard 2x5 connector
- SLUFDM-ADPT-C for modules with Hirose 9-pin connector (preliminary, inquire for availability)

## 8.0 Product Marking

An STEC Manufacturing Label is applied to the finished product. The label's post-printed information is described in the tables below, and label is shown in Figure 6.

Table 21: Label Post Printed Fields

Customer P/N (Human Readable)	Customer P/N (Bar Code)	STEC Item No. (BOM Assembly No.)	STEC P/N	Mfg. Date Code (Kanban ID)	Mfg's Logo	Capacity
Optional	Optional	See Table 22	As listed in Ordering Information	See Table 23		As Listed in Ordering Information

Table 22: BOM Assembly Number Information

BOM Assembly Number (Format: ppp00-0xxxx-yyzT(C/I)U)	Description
ppp00	STEC designation for OEM Flash products (ppp is 940 for standard, or customer prefix for custom)
0xxxx	PCB number
yy	Product Revision
z	Capacity Designator (Randomly assigned per PCB number based on designator availability)
T	Model Revision
C, I	Commercial and Industrial Operating Temperature
U	RoHS Compliant

Table 23: Kanban ID Information

Kanban ID (Format: yymmdd-XXX-xxx)	Description
yymmdd	Date code of manufacturing
XXX	SMT Line at which the part was manufactured
xxx	lot code

**STEC USB FLASH MODULE LABEL SPECIFICATION**

**1. Label Outline and Dimensions      2. Designated Post-printable Areas**

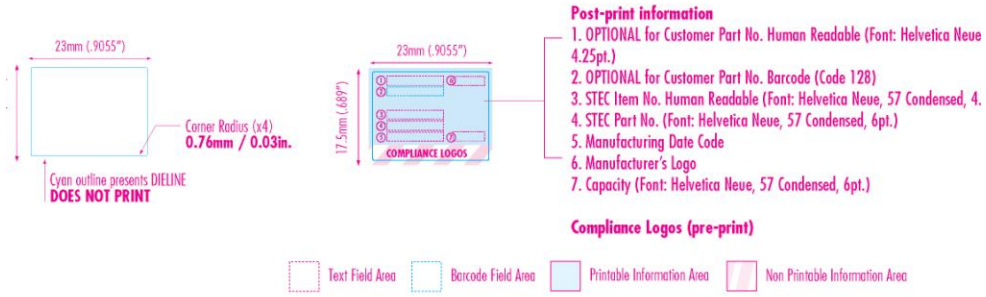

**3. Pre-printed content and sample      4. Post-printed content and sample**



**6. Label Material Information**

<b>MATERIALS:</b>	2 mil white uncoated mylar Glossy Finish	1 mil transparent adhesive UL/CSA Approved	UV inks
<b>COLOR PALLETTE:</b>	<input type="checkbox"/> One Color Process BLACK	<input checked="" type="checkbox"/> PMS: PMS 429c	
<b>LABEL ORIENTATION:</b>	Bottom of label comes off roll first		
<b>NOTES:</b>	Label is to be place on bottom of drive		

**STEC USB FLASH MODULE LABEL SPECIFICATION**  
 REVISION: B  
 REVISION DATE: DECEMBER 2010  
 SPECIFICATION #: 62100-00050-001  
 LABEL PART #: 74510-00256-001  
 PRODUCT MANAGER: SCOTT PHILLIPS  
 SPEC DESIGNER: TODD PICQUELLE

THIS INFORMATION IS CONFIDENTIAL AND PROPRIETARY TO STEC AND SHALL NOT BE REPRODUCED OR OTHERWISE DISCLOSED TO ANYONE OTHER THAN STEC EMPLOYEES WITHOUT WRITTEN PERMISSION FROM STEC.

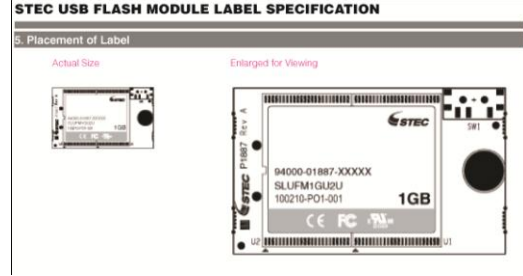

Figure 6: Label Specification

## 9.0 Programmed Vendor and Product Names

The USB Flash Module can be manufactured with standard or customer-specific Vendor and Product Names. Table 24 lists the STEC standard names for USB Flash Module.

The names can be displayed by the OS, for example, Windows XP displays the names in the notifications area in the right corner of the screen the first time the module is installed. Windows Device Manager and the properties of the USB Flash Module also can display the names

Table 24: STEC Standard USB Vendor and Product Names

Parameter	Value
Vendor Name	"STEC"
Product Name	"STEC USB 2.0"

## 10.0 Contact Information

### 10.1 STEC Worldwide Headquarters

STEC INC		
3001 Daimler Street	General Support:	1-949-476-1180
Santa Ana, California 92705	Fax Number:	1-949-476-1209
United States of America (USA)	E-mail:	oemsupport@stec-inc.com

### 10.2 STEC Worldwide Locations

STEC ITALY S. R. L.	STEC TAIWAN	STEC JAPAN G.K.
Via del Caravaggio, 3 20111 Milano Italy	RM1101, 11F, No. 495 Guang-Fu S. Road Taipei Taiwan	Shinyurigaoka-City Building 4-402 1-1-1, Manpukuji, Aso-ku, Kawaski-shi Kanagawa-ken 215-0004 Japan
Phone: +39 02 497 56 213	Phone: +886 2 8780 8000 Ext. 1101 Fax: +886 2 8725 7711	Phone: +81 44-959-2883 Fax: +81 44-959-2887
STEC MALAYSIA	STEC CHINA	
STEC Technology Sdn Plot 107 Bayan Lepas Industrial Park Phase 4 11900 Penang, Malaysia	RM1805, 18F Bund Centre 222 Yan An Road East HuangPu District Shanghai 200002 P.R. China	
Phone: +60 (4) 8887888	Phone: +86 21 6132 3892 Ext. 629 Fax: +86 21 6335 1336	

## 11.0 Revision History

<b>Revision</b>	<b>Date</b>	<b>Description</b>
-101	02/15/2011	Preliminary release.
-102	02/23/2011	“T” designator added to BOM Assembly Number. Extended changed to Industrial Temperature.
-103	04/08/2011	UBER, Endurance, and ECC Engine corrected (paper error only).
-104	06/07/2011	Logo updated. “1-High” replaced by Planar when describing flash placement. Preliminary notice removed.
-105	07/07/2011	Product Marking section updated.

**DISCLAIMER OF LIABILITY**

STEC™ Inc. reserves the right to make changes to specifications and product descriptions such as but not limited to numbers, parameters and other technical information contained herein without notice. Please contact the STEC™ Inc. sales office to obtain the latest specifications. STEC™ Inc. grants no warranty with respect to this datasheet, neither explicit or implied, and is not liable for direct or indirect damages. Some states do not grant the exclusion of incidental damages and as such this statement may not be valid in such states. The provisions of the datasheet do not convey to the purchaser of the device any license under any patent rights or other intellectual property rights of STEC Inc. or others.

**EXPORT ADMINISTRATION REGULATIONS**

The information provided may be subject to United States Export Controls. Such information should not be downloaded or exported (i), into (or to a national or resident of) Cuba, Iraq, Libya, North Korea, Iran, Syria, or any other country to which the United States has embargoed goods; or given to (ii), anyone on the United States Treasury Department's list of Specially Designated Nationals or the U.S. Commerce Department's Table of Deny Orders. By using the information, you represent and warrant that you are not located in, under the control of, or a national or resident of any such country or on any such list.

**COPYRIGHT NOTICE**

Copyright © 2011 by STEC™ Inc. All rights reserved. Information contained in this document, including but not limited to any instructions, descriptions and product specifications, is considered proprietary and confidential to STEC™, Inc. and shall not be modified, used, copied, reproduced or disclosed in whole or in part, in any form or by any means, electronic or mechanical, for any purpose, without the written consent of STEC™ Inc